

Gypsum Plasterboard Ceilings with BEKA Heating and Cooling Mats

1. General Information

Suspended gypsum plasterboard ceilings can very easily and economically be designed as heating and cooling ceilings with BEKA heating and cooling mats. Contemporary office and computer technology combined with a high degree of thermal insulation make it necessary to air-condition offices and business premises nearly all year round. Even during periods when heating is required, these rooms have a comparatively low heat consumption. The most cost-effective solution with regard to energy is the installation of a BEKA cooling and heating ceiling. The combined functionality of the ceiling minimises the investment required for the necessary building technology.

2. System Description

The BEKA capillary tube mats are simply stretched between the supporting profiles and covered with mineral wool. Afterwards, the ceiling is planked as usual - (standard cooling capacity 65 W/m²)

3. Cold-water/Hot-water Technology

The BEKA heating and cooling mats are integrated in rooms/zones in a tubing network as a circulation loop and connected to a cold-water generator and the heat source. We recommend that the connection is made using a BEKA single-storey distributor.

A wide variety of technologies and systems may be used for cold water generation. The economic advantages of the cooling ceiling consist primarily of the fact that the ceiling is extremely efficient even at flow temperatures which are only slightly below the room temperature. This facilitates the use of "alternative energy" (heating pumps) and natural energy (e.g. free cooling, groundwater).

The same advantages apply to hot water generation. Significant energy savings are achieved not only in combination with solar heating systems, but with conventional technology as well,

since even at low flow temperatures (below 40° C), the respectable calorific output can be used for heating.

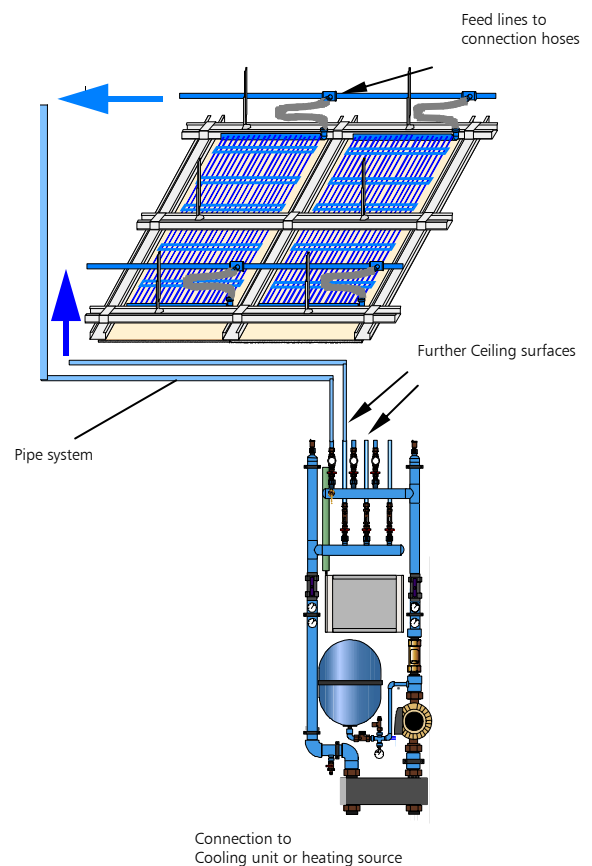

4. Installation

As a rule, the general installation guidelines apply. All materials used in the tubing network of the BEKA capillary tube mats must be made of non-corrosive materials. Plastics, stainless steel, copper, brass and red bronze may be used. Other materials may cause the system to silt up and thus disrupt its function.

5. Control Technology

The control technology ensures the comfort you desire and provides the necessary system safety as well.

The cooling ceiling requires a room temperature control unit, a dew point safeguard control unit and a control unit for the initial flow temperature of the cold water. Initial flow temperatures below 16°C must be avoided due to the dew point risk!

The heating ceiling requires a room temperature control. This regulates the flow of hot water depending on the desired room temperature. Initial flow temperatures more than 45°C must be avoided so that the surface temperature of the ceiling does not become too high, and the gypsum plasterboards dry out !

6. Dimensioning of the System

The BEKA heating and cooling mats are sized according to the following design tables. The initial flow temperature in the water circulation of the BEKA mats is set by adjusting the water temperature in front of the heat exchanger on the cold generator or heat generator side.

7. Installation Preparation

The stipulations of the dry construction guidelines and the regulations of the fitters' union apply to the assembly and mounting of the BEKA heating and cooling mats on gypsum plasterboard ceilings.

We recommend that the furring be carried out using torsionally rigid steel profiles. The specification of the effective spans and the execution of anchoring the hangers on the bare ceiling must be designed for a load of $\leq 30 \text{ kg/m}^2$.

Gypsum plasterboard sheets in the customary dimensions are used. The BEKA heating and cooling mats are supplied in the correct widths and lengths, so that cutting them to size on the construction site is not necessary. Inactive areas are arranged only around the edges and in places where ceiling fittings are planned.

Before beginning work, a ceiling drawing and a laying plan must be drawn up, in which all coffers with their dimensions, alignment, and the supply lines must be recorded. In the ceiling drawing, all areas must be also marked which must remain unoccupied, e.g. where partition walls, lighting and other ceiling fittings will be installed. In addition, the location where the BEKA M.TG.1 dew point sensor will be installed must also be marked in the ceiling drawing.

If thermal plastic welding is being used to connect the polypropylene tubes, the welding guideline DVS 2207-11 of the Deutscher Verband für Schweißtechnik e.V. (German Association of Welding Technology) applies. (The environment temperature during processing may not be lower than 5°C and the preheating, welding and holding times must be observed according to the dimensions of the tubing.)

8. Tools, Materials

The conventional tools and materials used in dry construction are used for the installation of the gypsum plasterboard ceiling covered with BEKA mats:

- CD profiles
- Cross connectors
- Vernier hangers
- Dowels and screws
- Dry wall screws, 25mm long
- (Only variation B) dry wall screws, 40 mm long
- Wetting angle
- Possibly a blade knife for cutting to size and an edge-trimming plane
- Screwdriver
- Spatula
- Joint filler
- Hand grinder

To connect the feed lines to the cold water circulation, a handheld welding unit with a sleeve mirror is used for plastic welding and the corresponding plastic fittings are required. Cutting ring screw fittings may be used as an alternative.

9. Steps in Assembling the Ceiling

- In accordance with the manufacturer's instructions, the supporting and basic profiles are attached to the bare ceiling using vernier suspenders and aligned. The distance between the supporting profiles must be set at 40 or 50 cm. Additional supporting profiles (including the wetting angle) in the area around the edge for the inactive custom-cut sheets are arranged according to the ceiling plan in accordance with the dry construction guidelines.
- The feed lines are laid in the hollow cavity of the ceiling and connected to the supply lines (connection by means of thermal plastic welding or cutting ring screw fittings).

I.

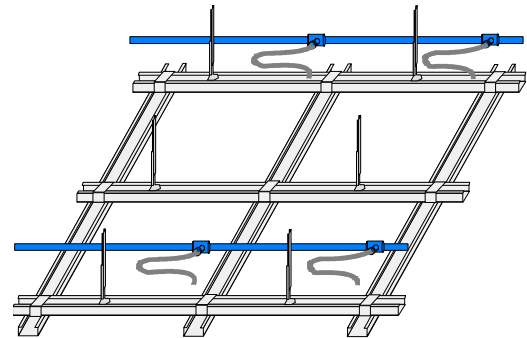

- The BEKA mats are stretched between the supporting profiles and connected to the feed lines via the flexible hoses; alternatively, the mats can be connected to each other and to the tubing system using plastic welding.
- Adhesive tapes are fastened from supporting profile to supporting profile, so that the mats do not sag.
- Mineral wool mats are laid on top of the BEKA mats from above. The mineral wool must be cut to fit as a strip in the grid dimension of the supporting profiles. If the hollow ceiling cavity is used for the exhaust ventilator or if perforated gypsum board is used, the mineral wool must be packed in fibreproof PE foil wrapping.

II.

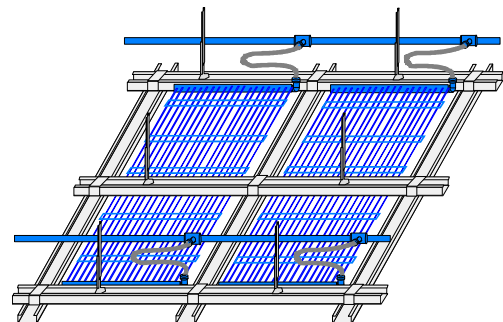

- The supporting structure is planked from below with gypsum board and filled.
- Preliminary test with 10 bars of compressed air for 1 hour.
- Main test with 10 bars of water for 4 hours – maintain resting pressure of 3 bars until the system is put into operation.

III.

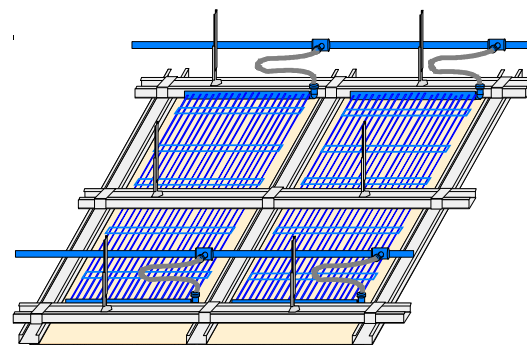

10. Lay-out for BEKA Mats on Gypsum Plasterboard in the Cooling Ceiling

Project:	Date :
Project consultant:	Lay-out valid for 27°C-room temperature and 2K cooling water spread !

Required Cooling Capacity

1 Room cooling load	W		from calculation of the planning office
2 Planned coverage with mats	qty		Max. possible arrangement derived from the room dimensions
3 Required cooling capacity	W		= Cooling load / Coverage

Determination of Performance

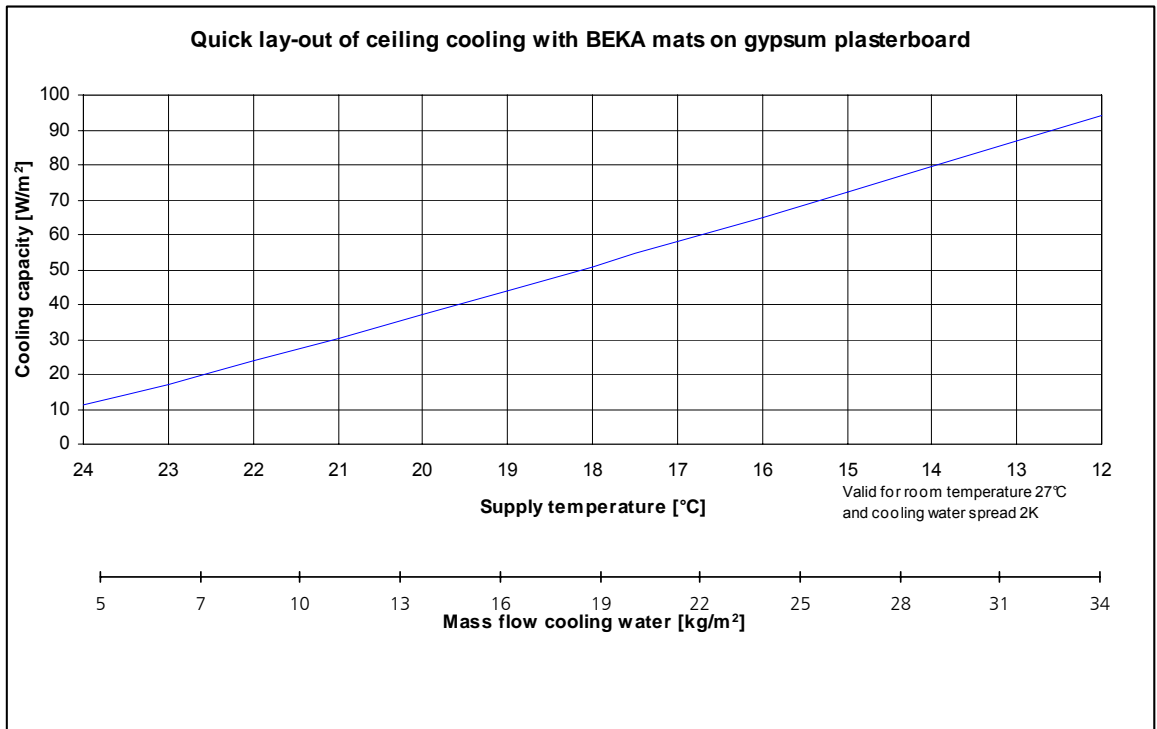

4 Supply temperature -> from diagram 1	°C	
5 Return temperature	°C	
6 Water volume per mat area	kg/m²h	
7 Water volume per zone	l/h	

Pressure loss calculation

8 Length of connecting tube	m	
9 Resistance in the tube -> from diagram 2	Pa/m	
10 Pressure loss in the tube = tube length * Resistance	Pa	
11 Pressure loss of the mat -> with value of line 2 from diagram 1	Pa	
12 Add. for pressure loss through fittings (recomm: 30% addition to tube)	Pa	
13 Add. for heat transfer stations (recomm: for zone valves 500-1000 Pa for mains regulating valves 700 - 1500 Pa for heat exchanger approx. 4000 Pa)	Pa	
14 Total pressure loss	Pa	

*If BEKA heat transfer stations are utilised the determination of pressure loss can be omitted.
In this case only the quantity of cooling circuits and the total cooling capacity is required for the selection !*

Pressure loss in the pipe 20x2mm

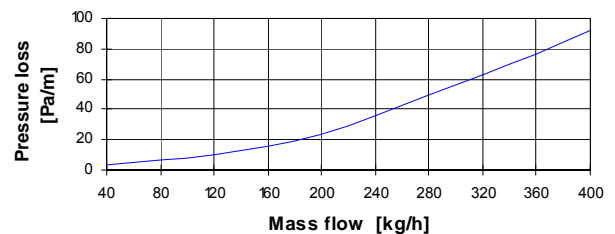

Pressure loss type G10

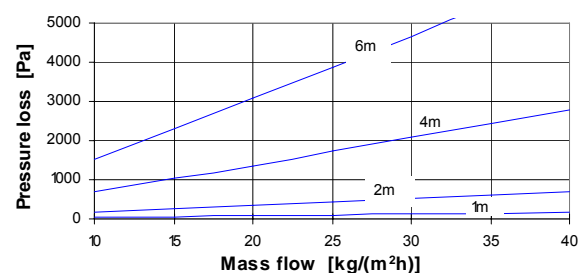

11. Layout for the BEKA Mats on Gypsum Plasterboard in Heating Ceiling

Project :	Date :
Project consultant :	Lay-out valid for 22°C -room temperature and 6 K hot spread!

Required heating capacity

1 Room heat requirement	W	from calculation of planning office
2 Planned coverage of mats	qty	max. possible arrangement derived from room dimensions
3 Required specific heat capacity	W	= Heating requirement /Coverage

Determination of Performance

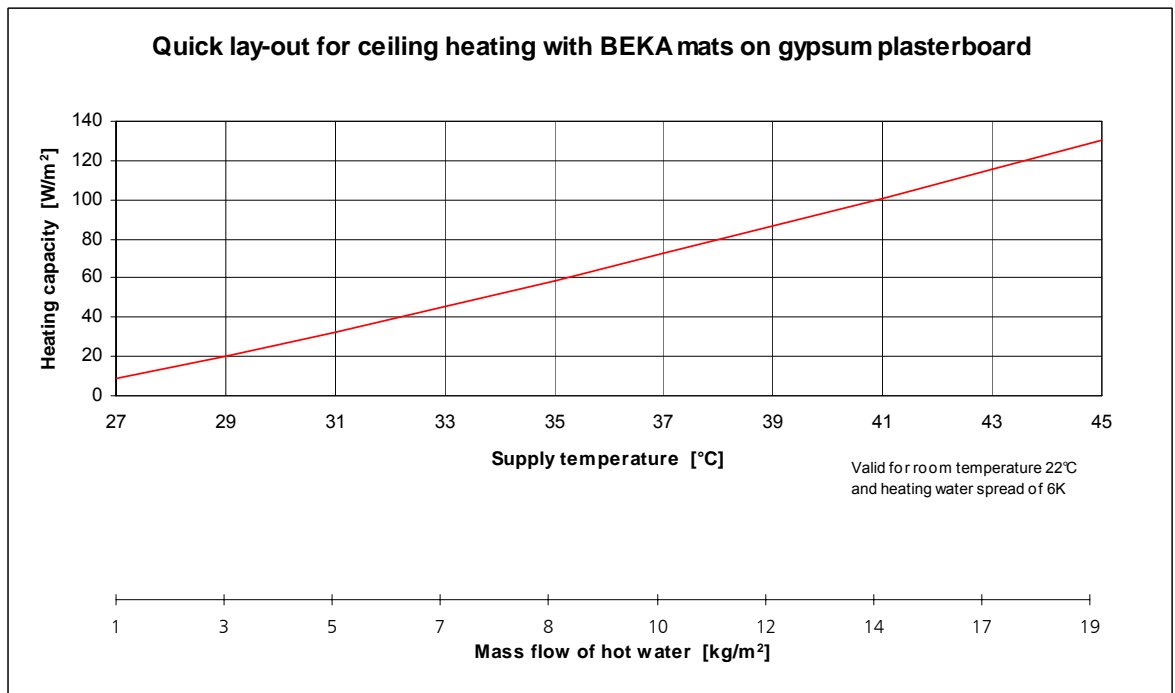

4 Supply temperature → from diagram 1	°C	
5 Return temperature	°C	
6 Water volume per mat area	kg/(m²h)	
7 Water volume per zone	l/h	

Pressure loss calculation

8 Length of connecting pipe	m	
9 Resistance in the pipe → from diagram 2	Pa/m	
10 Pressure loss in the pipe = Pipe length* Resistance	Pa	
11 Pressure loss of the mat → with value from line 2 in diagram 1	Pa	
12 Add. for pressure loss through fittings (recomm: 30% addition to pipe)	Pa	
13 Add. for heat transfer station (recomm: for zone valves 500 - 1000 Pa for mains regulating valves 700 - 1500 Pa for heat exchanger approx. 4000 Pa)	Pa	
14 Total pressure loss	Pa	

If BEKA transfer stations are used, the pressure loss calculation is omitted. Only the number of heating circuits and the total heating capacity are required for the selection.

Pressure loss in the pipe 20 x 2 mm

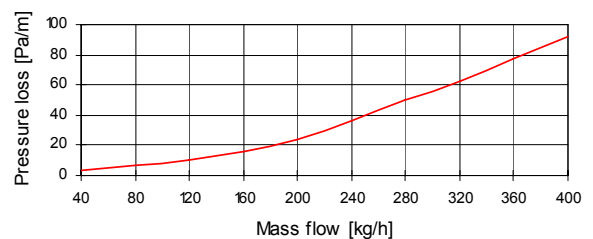

Pressure loss type K.G10

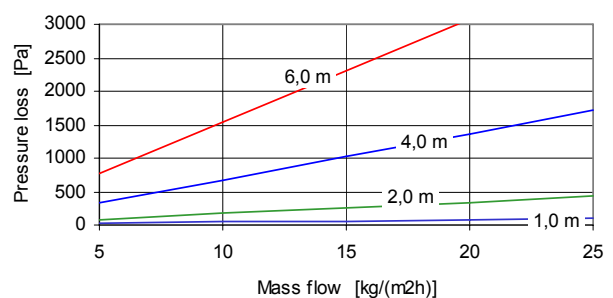

12. Technical Specifications

BEKA capillary tube mats
Type K.G10/K.GK10

Material

Polypropylene random copolymerisate Type 3 DIN 8078

Geometry

Collection tube	20 x 2 mm
Capillary tube	3.35 x 0.5 mm
Capillary tube interval	10 mm
Exchange surface	1.067 m ²

Size

Length: 600-6000 mm (in steps of 10 mm)
Width: 230- 430 mm (in steps of 10 mm)

Volume

0.430 kg/m² (unfilled, without collector)
0.824 kg/m² (filled, without collector)
Water content 0.39 l/m²

Cooling capacity:

65 W/m² with 10 mm gypsum plasterboard
(heat conductivity of the thermal sheet approximately 0.40 W/mK)

Heating capacity:

Up to 130 W/m²

Operating conditions:

Temperature-stable in continuous use up to 45°C
Operating pressure 3 to 4 bars
Test pressure 10 bars for a maximum of 10 hours

Field of application/Laying method:

Cooling and heating ceilings in dry construction
Connection via flexible hoses and quick-coupling connectors
or via thermal plastic welding

Form of delivery:

The mats are rolled and delivered in cartons.